

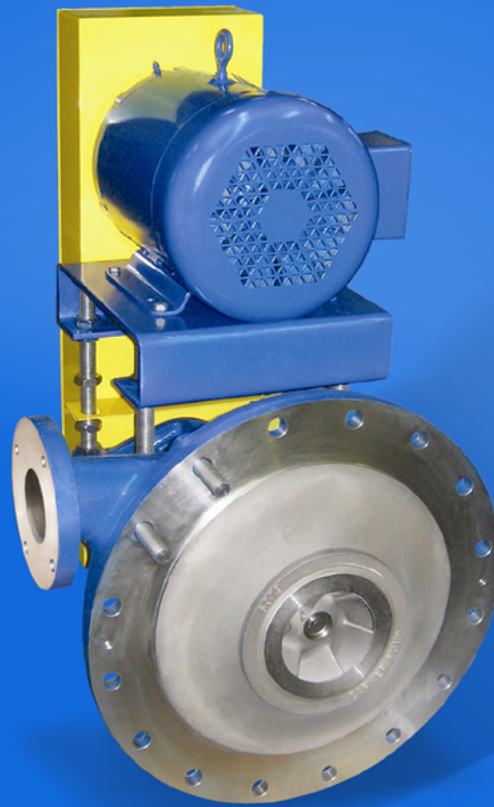

CARVER PUMP™

Built for purpose



855

Filtrate Pump



ALSO FOR THE FILTRATE MARKET



The 850 is specifically designed for filtration systems and abrasive fluid processes. It is available as either a close-coupled or frame-mounted unit, with an option for a side-mounted motor with belt drive.



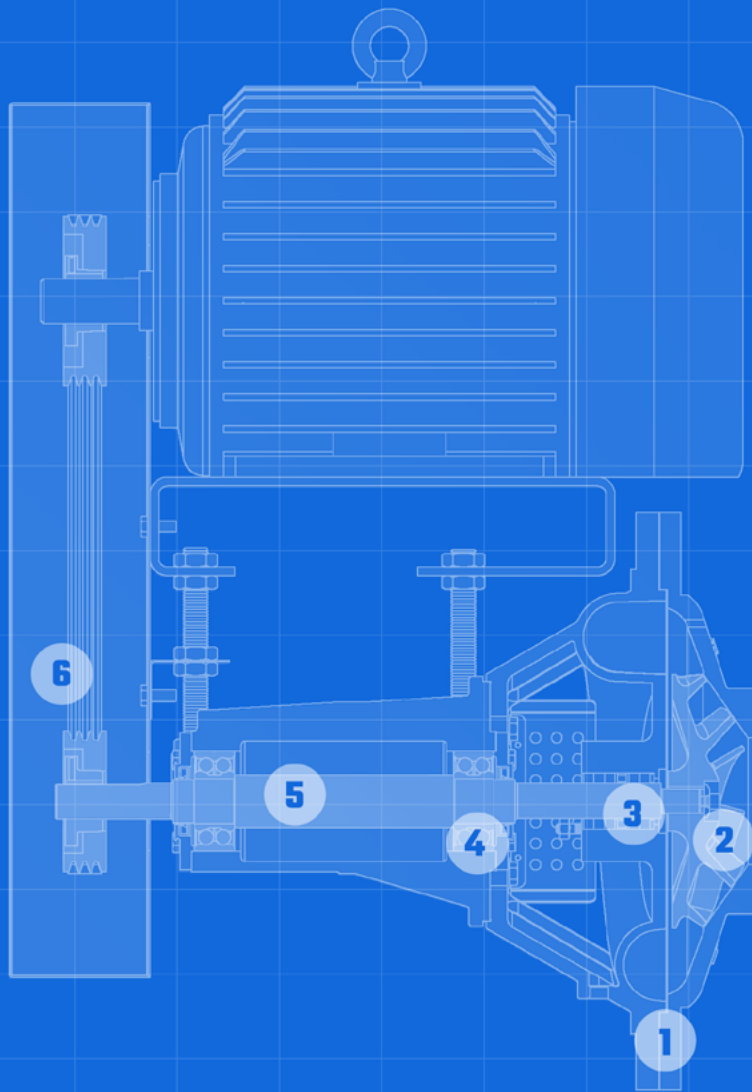

1

MOUNTING

Flange mounting directly to the receiver tank eliminates suction piping and diminishes NPSH problems. The design allows pumping to resume even after short periods of interrupted flow

2

IMPELLERS

Semi-open impellers are keyed to the shaft for secure fit

3

STUFFING BOX

Packed stuffing box as standard, mechanical seals are available as an option

4

BEARINGS

Sealed-for-life ball bearings on both the inboard and outboard locations ensure a long, low-maintenance life. (Single, sealed-for-life ball bearings are used on 1" x 8" model)

5

SHAFTS

Stainless steel shafts for corrosion resistance

6

BELT DRIVE

System includes motor mounting plate, adjusting rods, belts, sheaves and guard

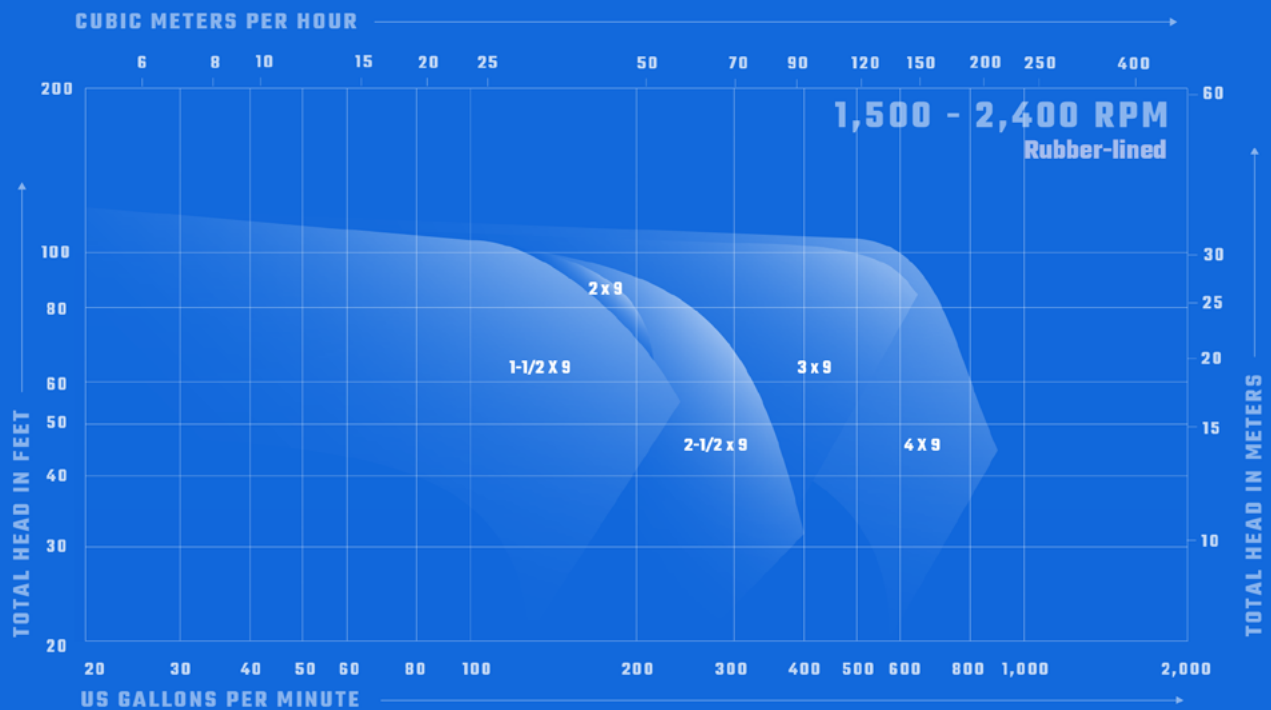
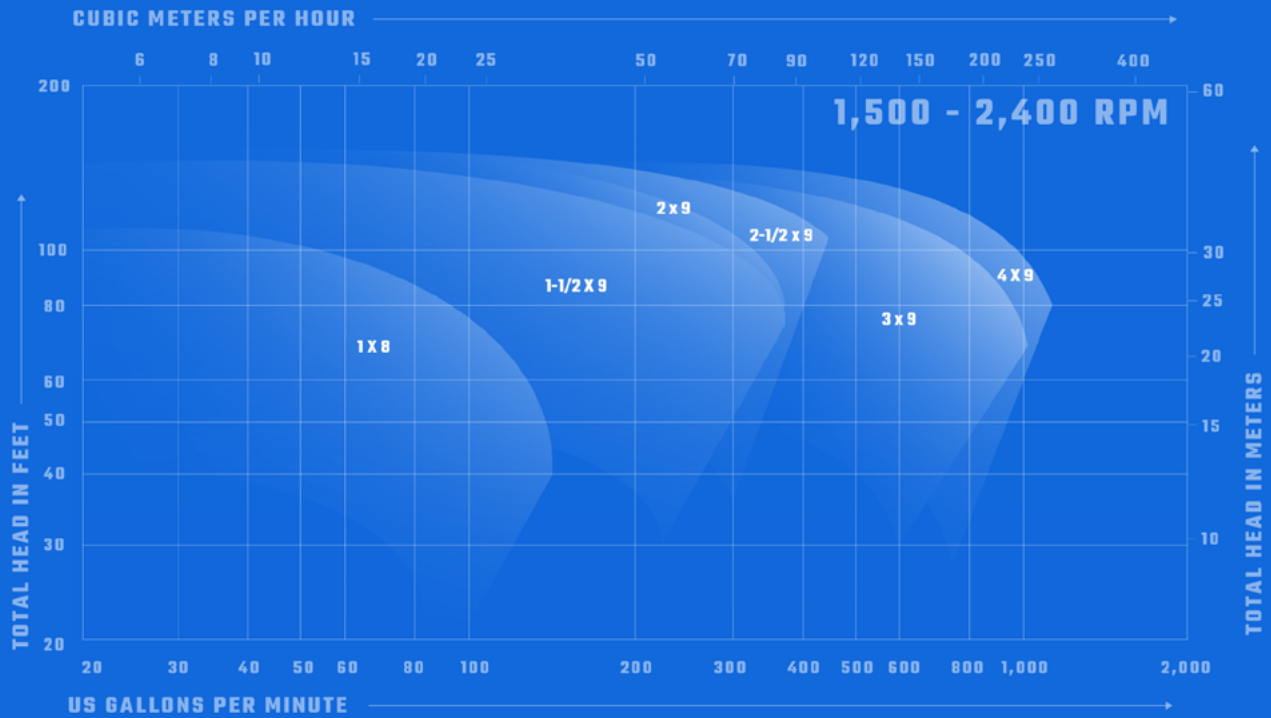

Intertek

WHY AN 855?

- Handles challenging suction conditions.
- Optional swing-out mount allows for pump inspection and quick access to tank.
- Unit speed can be adjusted through a VFD or belt drive, to fine tune performance to match system requirements.
- The casing is self-venting, to prevent airlock.

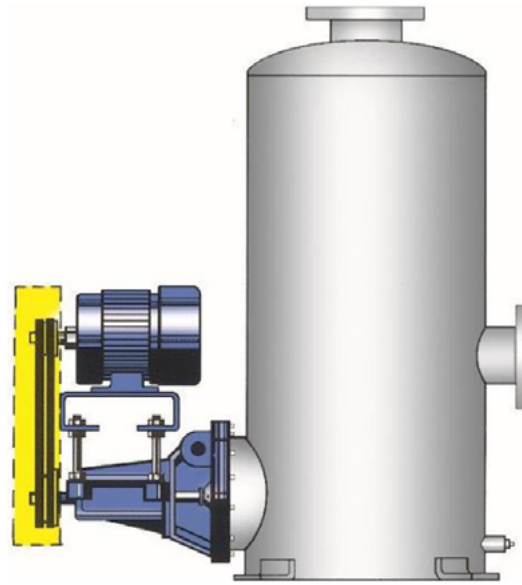

HYDRAULICS

- Flows to 700 US GPM (159 m³/hr)
- Heads to 120 feet (36 m)
- Power to 20 HP (15 KW)
- Temperatures to 250° F (121° C)
- Speeds to 2,450 RPM

APPLICATIONS

- Minerals & Mining
- Power Generation
- Pulp & Paper
- Light Abrasives
- Condensate Systems

STANDARD MATERIALS

Casing	Cast Iron, CD4MCuN, or Rubber-Lined
Impeller	Cast Iron, CD4MCuN, or Rubber-Lined
Shaft	Duplex SS or 17-4PH SS
Bearing Frame	Cast Iron

Other materials available upon request.

MECHANICAL DATA

Rotation	Counter Clockwise
Input Power	Up to 20 HP
Discharge Connection	Flanged Class 150 ANSI and DIN PN10
Bearings	Greased for Life

855

Specifically designed to meet the needs of filtrate pump users.

This model was originally developed for a large Original Equipment Manufacturer (OEM) of vacuum filtration equipment. Mounting the flange directly to the receiver tank eliminates suction piping and minimizes NPSH problems. The design allows pumping to resume even after short periods of interrupted flow. Capable of operating in vacuum conditions up to 26" Hg, the specially designed semi-open impeller assures pumping from a trickle to full capacity. Rugged in design and dependable in nature, the 855 is a workhorse in some of the toughest environments in the industry.

The 855 features an overhead v-belt drive arrangement as standard, with options for close-coupled units. By utilizing either belt drive or variable frequency drive, performance characteristics can be fine-tuned to match most system requirements. With a simple, vertically-split case design, the 855 may be disassembled to expose the entire wetted area. Standard features include a packed stuffing box with seal water connections provided, to ensure lubrication and eliminate vacuum/air leakage. Pumps come with discharge flanges machined for both Class 150 ANSI and DIN PN10 connections.

Corrosion-resistant shafts are used to eliminate the need for shaft sleeves. Impellers are keyed to the shaft, providing a secure fit and protection, should momentary reverse rotation occur. The swing-out mount is a popular optional feature allowing easy inspection of the pump and quick access to the tank interior.

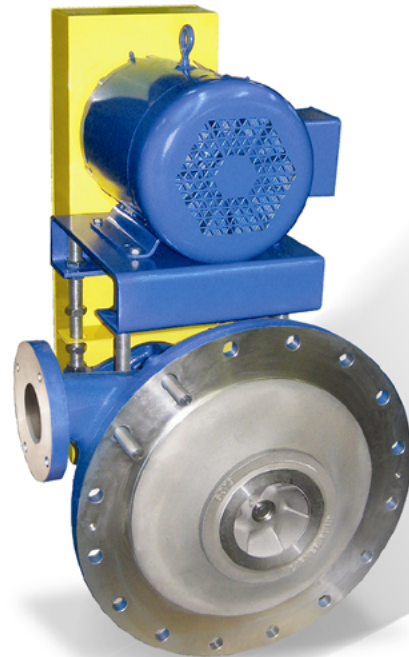

855



60 YEARS OF SUCCESS IN THE FILTRATE PUMP MARKET

Our 855 has become the go-to pump for OEMs in the filtrate market. Built to operate in harsh pumping environments, the 855 mounts directly to the receiver tank of vacuum pump filtration systems found primarily in the power generation, mining, and pulp & paper industries.



80 years of experience

Since we built our first pumps, Carver Pump has become recognized as one of the leading centrifugal pump companies, building to the most demanding engineering specifications and military standards in the world.

We were one of the first American pump companies to attain ISO 9001 certification – the most recognized standard for quality in the world. This certification is your assurance that our commitment

to quality includes not only our hardware, but also superior customer service, leading-edge R&D, and continuous improvement in everything we do.

So whether the job is refueling fighter jets on the deck of an aircraft carrier, supplying paint to an auto assembly line, or bringing water to the fountain in a city park, we put our reputation on the line everyday with every pump we build.

Contact us

2415 Park Avenue
Muscatine, Iowa 52761-5691
USA

(563) 263-3410
sales@carverpump.com
www.carverpump.com

DISTRIBUTED BY:



Polígono Beotibar, 33
20491 Belauntza
+34 943 67 16 61
okobio@okobio.com
www.okobio.com